



Winpak Lane, Inc.

1365 N. Ayala Drive, Rialto, CA 92376 USA Tel: 909.885.0715 Fax: 909.381.1934

Email: sales2@winpak.com

www.winpak.com

The Winpak Lane model W-18 is a high output vertical-form-fill-seal pouch/sachet packaging machine. The worlds largest food companies use Winpak Lane machines exclusively as they are well known for their high output, efficiency and quality. With production rates reaching 1500 pouches per minute and a machine designed to run continuously. Often 24 hours per day, 6 days per week. Winpak Lane is the prerequisite for today's competitive environment.

Features Include:

- Precision servo drive system
- Accurately fills a wide variety of products
- "Atmospheric Control" option provides a reliable hot-fill solution
- Film web width of up to 20" (508 mm)
- Particulates up to 1/2" (12 mm)
- Product tank , valve, and piping options available
- Change parts available to convert to three-sided seal ("stick pack")
- User-friendly packaging features and options such as notches, perforations, pouring spouts, etc.
- Save each recipe by SKU for quick repeatable changeovers
- Powered knife height adjustment
- Tool-less fill tube height adjustment
- Field-configurable optional controls



W-18	
FILM WIDTH	Up to 20" (508 mm)
PACKAGES PER CYCLE	2 to 14
PACKAGE WIDTHS	Minimum 1.36" (34.5 mm) Maximum 9" (228.6 mm)
PACKAGE LENGTHS	Minimum 2" (50 mm) Maximum 12" (305 mm)
CYCLES PER MINUTE	15 to 120
FILL VOLUME RANGE	Minimum 0.1 fl. oz. (3 ml) Maximum 32 fl. oz. (946 ml)
FILL TEMPERATURE RANGE	Minimum 34° F (1° C) Maximum 195° F (90° C)

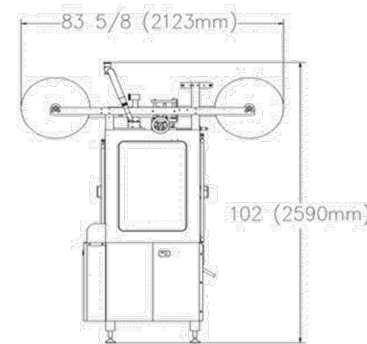
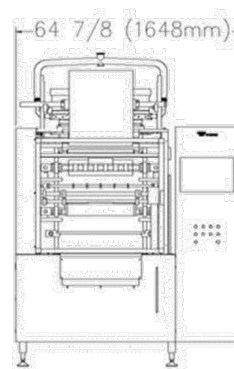
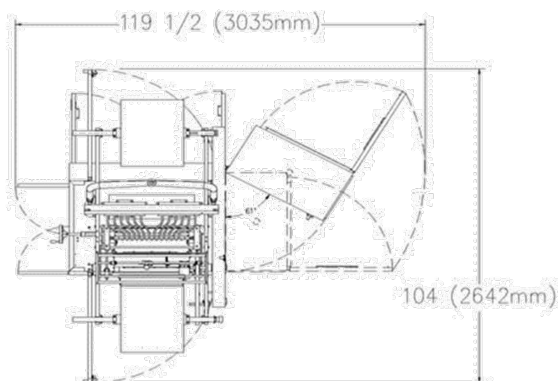

W-18 options include:

- Front and back registration systems
- Splice detector
- Specialized low viscosity fillers
- Thermal transfer or ink jet coding
- Packaging flow control gate



Winpak Lane, Inc.

1365 N. Ayala Drive, Rialto, CA 92376 USA Tel: 909.885.0715 Fax: 909.381.1934

Email: sales2@winpak.com

www.winpak.com