

**WINPAK**

TOTAL PACKAGING SOLUTIONS

**W-630**

**W-630AF**



**Winpak Lane, Inc.**

1365 N. Ayala Drive, Rialto, CA 92376 USA Tel: 909.885.0715 Fax: 909.381.1934

Email: [sales2@winpak.com](mailto:sales2@winpak.com)

[www.winpak.com](http://www.winpak.com)

# W-630 / W-630AF

The W-630AF vertical-form-fill-seal pouch machine is a 4-axis servo-controlled machine. The model W-630AF forms a single lap seal pouch per cycle. Precision servo controls make the W-630AF the accurate high output choice for bulk liquid applications.

- Servo driven, including:
  - Horizontal seals, for repeatable seal pressure
  - Pull wheels, for precise pouch lengths
  - Squeegee rollers, for accurate consistent fill weights
  - Pump: For consistent fill
- Robust construction with 6061 aluminum standard
  - 3A Dairy optional (W-630)
- Positive closed loop film unwind system for superior film tracking
- Thermal date coder or ink jet options
- Induction film splicing for quick, easy roll changes
- Independent temperature controls for seal
- Dispenser pack fitment capability
- On-line technical support
- Recipe-driven from user friendly HMI
- Pendant operator station for left or right hand operation



MODEL W-630 / W-630AF	
FILM WIDTH	Up to 24" (610 mm)
PACKAGE WEIGHT	1 to 25 lbs.
PACKAGE WIDTHS	6" to 11" (150 mm to 285 mm)
PACKAGE LENGTHS	6" to 27" (150 mm to 432 mm)
CYCLES PER MINUTE	Up to 50
PACKAGE STYLE	Lap seal pouch. Optional features include easy-open and fitments.
PRODUCTS PACKAGED	Pumpable liquids with or without particulates including: salad dressing, sauces, cheese, condiments, salsa.
LIQUID-FILLED POUCHES	Minimum 34 °F (1 °C) Particulate Size Up To 1-1/8" (30 mm) Zero head space pouches

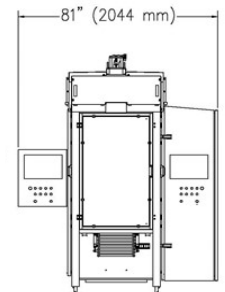
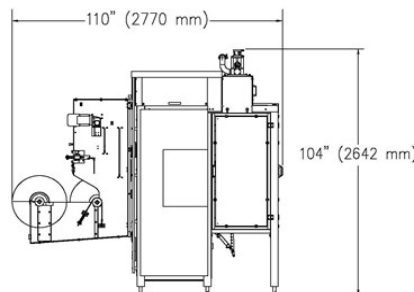
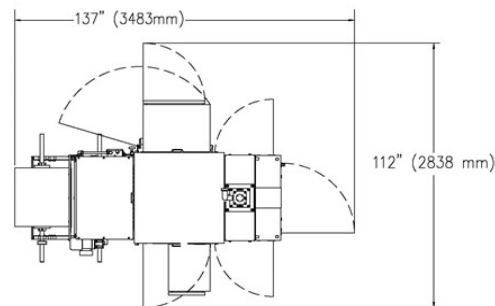

## WINPAK

Winpak Lane, Inc.

1365 N. Ayala Drive, Rialto, CA 92376 USA Tel: 909.885.0715 Fax: 909.381.1934

Email: sales2@winpak.com

www.winpak.com