



TOTAL PACKAGING SOLUTIONS

WC-4/5



Winpak Lane, Inc.

1365 N. Ayala Drive, Rialto, CA 92376 USA Tel: 909.885.0715 Fax: 909.381.1934

Email: sales2@winpak.com

www.winpak.com

Winpak WC 4/5 horizontal in-line fill/seal packaging machines are innovative cup machines designed to run preformed rectangular cups for a wide variety of applications.

Winpak offers a selection of models and options to produce maximum outputs from 320 to 700 packages per minute. With the capability to run a wide selection of products and packaging sizes, WC 4/5 machines are the perfect choice for nearly any product or application.

- Multiple machine models and options are available to match production needs and/or a wide variety of product or applications.
- Highly reliable, small footprint machines
- Robust construction with NEMA 4X/IP65 components and enclosures
- Advanced control system and color touch screen operator interface
- Individual PID temperature controls
- Typical product applications include dips, condiments, sauces, dressings, margarine, jams, jellies, syrups, and many other liquid and semi-viscous products.



WC-4/5	
CUP SIZE	Width: 1-5/8" (41.3 mm) Length: 2-1/4" (57.2 mm)
CUP STYLE	Rectangular Preformed Plastic Cup Trays
PACKAGES PER CYCLE	8 or 10
LID STYLE	Roll Stock Lidding
MAX. CYCLES PER MINUTE	30 to 70
NOMINAL FILL VOLUME	Min: 1/2 fl. oz. (14 ml) Max: 2 fl. oz. (56 ml)
MAX. CUPS PER MINUTE	700 depending on product/application

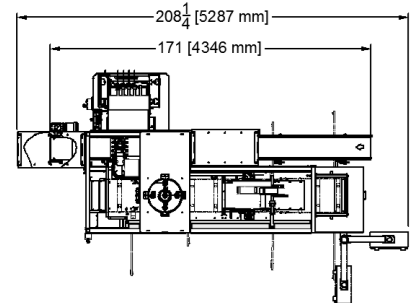

Other WC 4/5 options include:

- Opposite hand layouts
- Lid stock code dating
- Product tanks with controls
- Automatic case packers
- On-the-fly weight adjusters
- Bottom up fill system
- Particulate filler system
- Full CIP capable

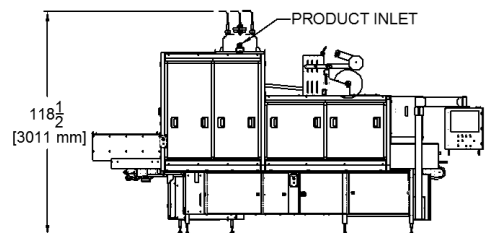
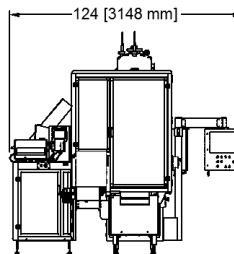

Winpak Lane, Inc.

1365 N. Ayala Drive, Rialto, CA 92376 USA Tel: 909.885.0715 Fax: 909.381.1934

Email: sales2@winpak.com

www.winpak.com